

DS34LV86T

DS34LV86T 3V Enhanced CMOS Quad Differential Line Receiver



Literature Number: SNLS115C

DS34LV86T

3V Enhanced CMOS Quad Differential Line Receiver

General Description

The DS34LV86T is a high speed quad differential CMOS receiver that meets the requirements of both TIA/EIA-422-B and ITU-T V.11. The CMOS DS34LV86T features typical low static I_{CC} of 9 mA which makes it ideal for battery powered and power conscious applications. The TRI-STATE® enables, EN, allow the device to be disabled when not in use to minimize power consumption. The dual enable scheme allows for flexibility in turning receivers on and off.

The receiver output (RO) is guaranteed to be High when the inputs are left open. The receiver can detect signals as low as ± 200 mV over the common mode range of ± 10 V. The receiver outputs (RO) are compatible with TTL and LVCMOS levels.

Features

- Low power CMOS design (30 mW typical)
- Interoperable with existing 5V RS-422 networks
- Industrial temperature range
- Meets TIA/EIA-422-B (RS-422) and ITU-T V.11 recommendation
- 3.3V Operation
- ± 7 V common mode range @ $V_{ID} = 3$ V
- ± 10 V common mode range @ $V_{ID} = 0.2$ V
- Receiver OPEN input failsafe feature
- Guaranteed AC parameter:
Maximum Receiver Skew: 4 ns
Transition time: 10 ns
- Pin compatible with DS34C86T
- 32 MHz Toggle Frequency
- >6.5k ESD Tolerance (HBM)
- Available in SOIC packaging

Connection Diagram

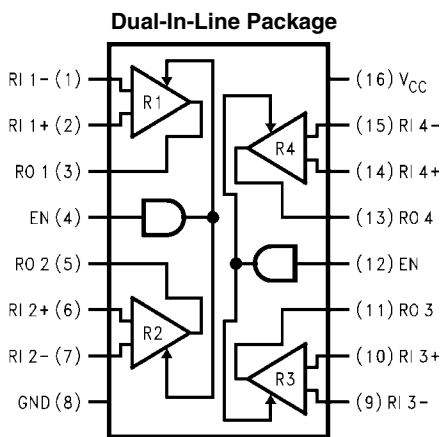

Top View
Order Number DS34LV86TM
See NS Package Number M16A

1264401

Truth Table

Enable EN	Inputs RI+–RI–	Output RO
L	X	Z
H	$V_{ID} \geq +0.2$ V	H
H	$V_{ID} \leq -0.2$ V	L
H	Open†	H

L = Logic Low
H = Logic High
X = Irrelevant
Z = TRI-STATE
† = Open, Not Terminated

Absolute Maximum Ratings (Note 1)

If Military/Aerospace specified devices are required, please contact the National Semiconductor Sales Office/ Distributors for availability and specifications.

Supply Voltage (V_{CC})	+7V
Enable Input Voltage (EN)	+7V
Receiver Input Voltage (V_{ID} : RI+, RI-)	±14V
Receiver Input Voltage (V_{CM} : RI+, RI-)	±14V
Receiver Output Voltage (RO)	-0.5V to $V_{CC} + 0.5V$
Receiver Output Current (RO)	±25 mA
Maximum Package Power Dissipation @ +25°C	
M Package	1190 mW
Derate M Package	9.8 mW/°C above +25°C

Storage Temperature Range	-65°C to +150°C
Lead Temperature Range	
Soldering (4 Seconds)	+260°C
ESD Ratings (HBM, 1.5k, 100 pF)	
Receiver Inputs and Enables	≥6.5 kV
Other Pins	≥2 kV

Recommended Operating Conditions

	Min	Typ	Max	Units
Supply Voltage (V_{CC})	3.0	3.3	3.6	V
Operating Free Air Temperature (T_A)	-40	+25	+85	°C

Electrical Characteristics (Notes 2, 3)

Over Supply Voltage and Operating Temperature ranges, unless otherwise specified.

Symbol	Parameter	Conditions	Pin	Min	Typ	Max	Units	
V_{TH}	Differential Input Threshold	$V_{OUT} = V_{OH}$ or V_{OL} $-7V < V_{CM} < +7V$	RI+, RI-	-200	±17.5	+200	mV	
V_{HY}	Hysteresis	$V_{CM} = 1.5V$			35		mV	
V_{IH}	Minimum High Level Input Voltage		EN	2.0			V	
V_{IL}	Minimum Low Level Input Voltage					0.8	V	
R_{IN}	Input Resistance	$V_{IN} = -7V, +7V$ (Other Input = GND)		5.0	8.5		kΩ	
I_{IN}	Input Current (Other Input = 0V, Power On or $V_{CC} = 0V$)	$V_{IN} = +10V$	RI+, RI-	0	1.1	1.8	mA	
		$V_{IN} = +3V$		0	0.27		mA	
		$V_{IN} = 0.5V$			-0.02		mA	
		$V_{IN} = -3V$		0	-0.43		mA	
		$V_{IN} = -10V$		0	-1.26	-2.2	mA	
I_{EN}		$V_{IN} = 0V$ to V_{CC}	EN			±1	μA	
V_{OH}	High Level Output Voltage	$I_{OH} = -6 mA, V_{ID} = +1V$ $I_{OH} = -6 mA, V_{ID} = OPEN$	RO	2.4	3		V	
V_{OH}	High Level Output Voltage	$I_{OH} = -100 μA, V_{ID} = +1V$ $I_{OH} = -100 μA, V_{ID} = OPEN$			$V_{CC} - 0.1$		V	
V_{OL}	Low Level Output Voltage	$I_{OL} = +6 mA, V_{ID} = -1V$				0.13	0.5	V
I_{OZ}	Output TRI-STATE Leakage Current	$V_{IN} = V_{CC}$ or GND EN = V_{IL}					±50	μA
I_{SC}	Output Short Circuit Current	$V_O = 0V, V_{ID} ≥ 200 mV $ (Note 4)			-10	-35	-70	mA
I_{CC}	Power Supply Current	No Load, All RI+, RI- = Open, EN = V_{CC} or GND		V_{CC}		9	15	mA

Switching Characteristics (Notes 3, 9, 10)

Over Supply Voltage and Operating Temperature ranges, unless otherwise specified.

Symbol	Parameter	Conditions	Min	Typ	Max	Units
t_{PHL}	Propagation Delay High to Low	$C_L = 15\text{ pF}$ (Figures 1, 2)	6	17.5	35	ns
t_{PLH}	Propagation Delay Low to High		6	17.8	35	ns
t_r	Rise Time (20% to 80%)		4.1	10	ns	
t_f	Fall Time (80% to 20%)		3.3	10	ns	
t_{PHZ}	Disable Time	$C_L = 50\text{ pF}$ (Figures 3, 4)			40	ns
t_{PLZ}	Disable Time				40	ns
t_{PZH}	Enable Time				40	ns
t_{PZL}	Enable Time				40	ns
t_{SK1}	Skew, $ t_{PHL} - t_{PLH} $ (Note 5)	$C_L = 15\text{ pF}$		0.3	4	ns
t_{SK2}	Skew, Pin to Pin (Note 6)			0.6	4	ns
t_{SK3}	Skew, Part to Part (Note 7)			7	17	ns
f_{MAX}	Maximum Operating Frequency (Note 8)	$C_L = 15\text{ pF}$	32			MHz

Note 1: "Absolute Maximum Ratings" are those values beyond which the safety of the device cannot be guaranteed. They are not meant to imply that the devices should be operated at these limits. The table of "Electrical Characteristics" specifies conditions of device operation.

Note 2: Current into device pins is defined as positive. Current out of device pins is defined as negative. All voltages are referenced to ground except V_{ID} .

Note 3: All typicals are given for: $V_{CC} = +3.3\text{V}$, $T_A = +25^\circ\text{C}$.

Note 4: Short one output at a time to ground. Do not exceed package power dissipation ratings.

Note 5: t_{SK1} is the $|t_{PHL} - t_{PLH}|$ of a channel.

Note 6: t_{SK2} is the maximum skew between any two channels within a device, on either edge.

Note 7: t_{SK3} is the difference in propagation delay times between any channels of any devices. This specification (maximum limit) applies to devices within $V_{CC} \pm 0.1\text{V}$ of one another, and a $\Delta T_A = \pm 5^\circ\text{C}$ (between devices) within the operating temperature range. This parameter is guaranteed by design and characterization.

Note 8: All channels switching, output duty cycle criteria is 40%/60% measured at 50% Input = 1V to 2V, 50% Duty Cycle, $t_r/t_f \leq 5\text{ ns}$. This parameter is guaranteed by design and characterization.

Parameter Measurement Information

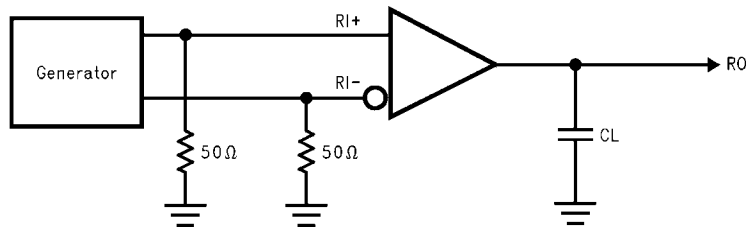

1264402

FIGURE 1. Receiver Propagation Delay and Transition Time Test Circuit (Notes 9, 10)

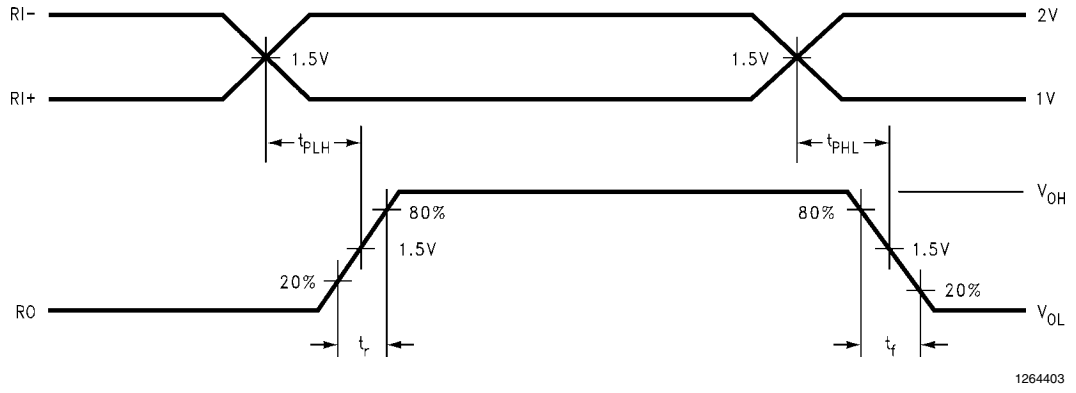

FIGURE 2. Receiver Propagation Delay and Transition Time Waveform (Notes 9, 10)

Note 9: Generator waveform for all tests unless otherwise specified: $f = 1 \text{ MHz}$, Duty Cycle = 50%, $Z_o = 50\Omega$, $t_r \leq 10 \text{ ns}$, $t_f \leq 10 \text{ ns}$.

Note 10: C_L includes probe and jig capacitance.

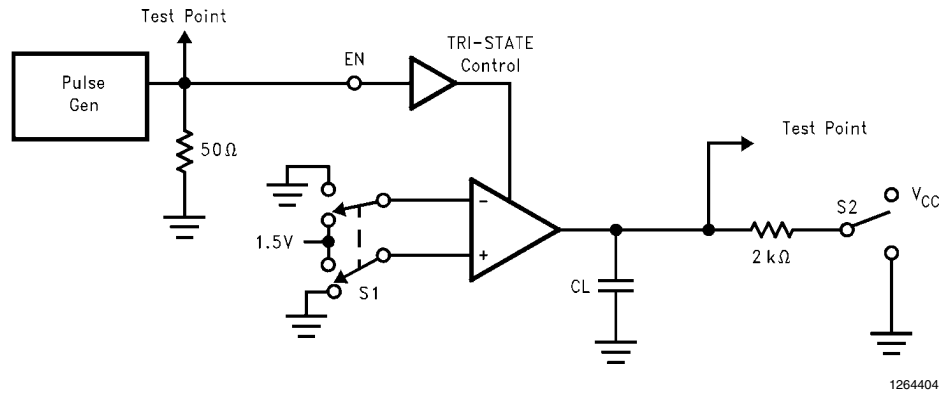

FIGURE 3. Receiver TRI-STATE Test Circuit

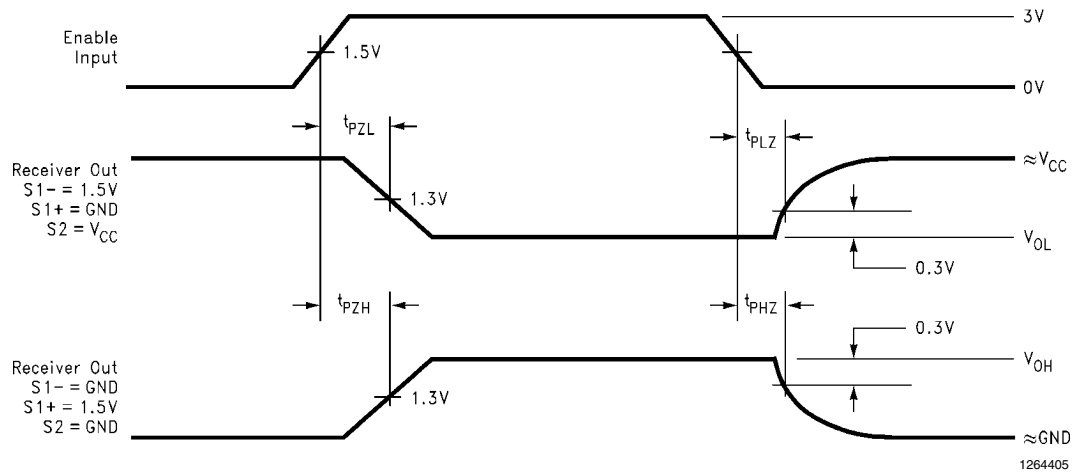

FIGURE 4. Receiver TRI-STATE Output Enable and Disable Waveforms (Notes 9, 10)

Typical Application Information

General application guidelines and hints for differential drivers receivers may be found in the following application notes:

AN-214, AN-457, AN-805, AN-847, AN-903, AN-912, AN-916

Power Decoupling Recommendations: Bypass caps must be used on power pins. High frequency ceramic (surface mount

is recommended) 0.1 μF in parallel with 0.01 μF at the power supply pin. A 10 μF or greater solid tantalum or electrolytic should be connected at the power entry point on the printed circuit board.

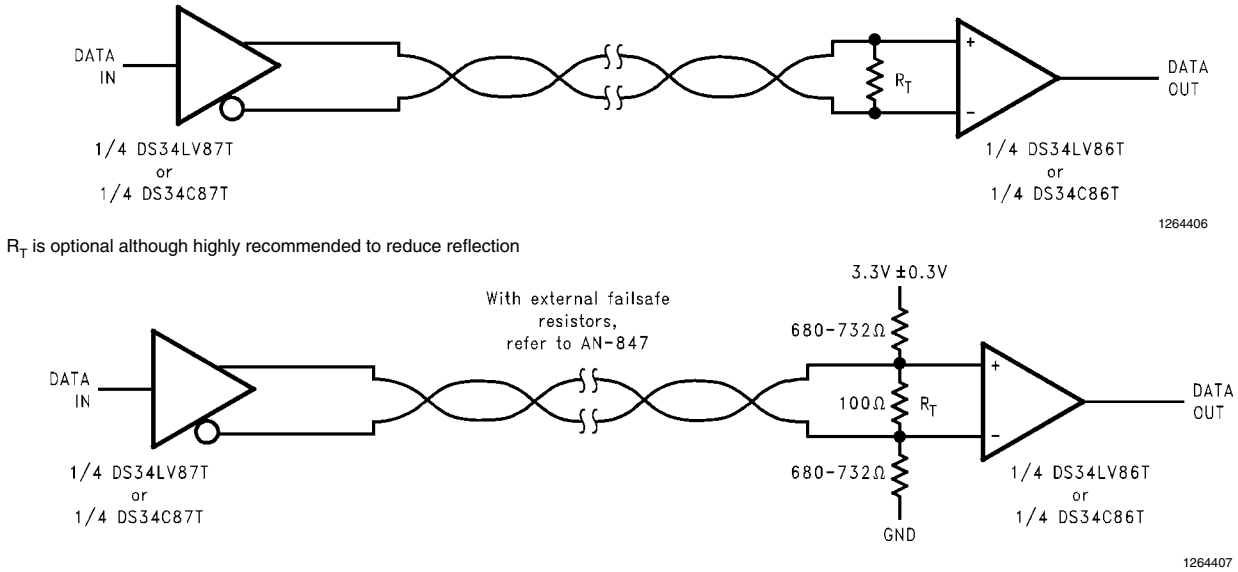

FIGURE 5. Typical Receiver Connections

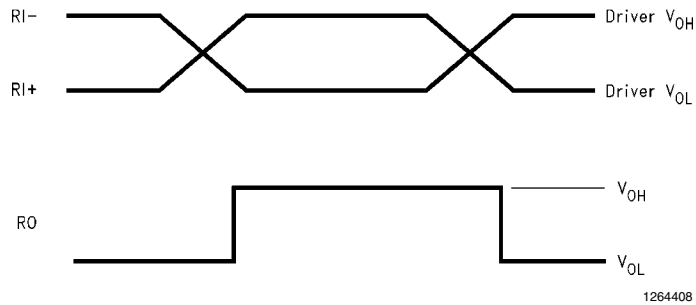
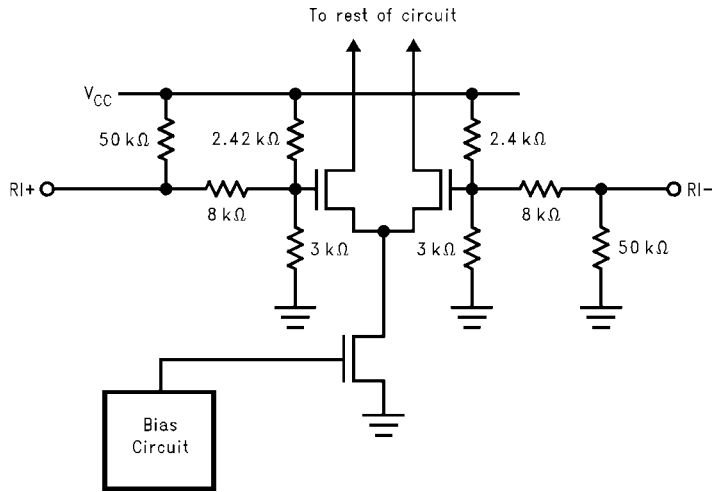
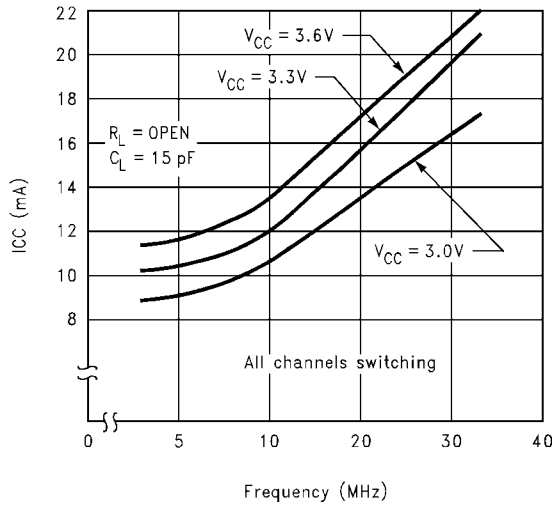

FIGURE 6. Typical Receiver Output Waveforms



1264409

FIGURE 7. Typical Receiver Input Circuit



1264410

FIGURE 8. Typical I_{CC} vs Frequency

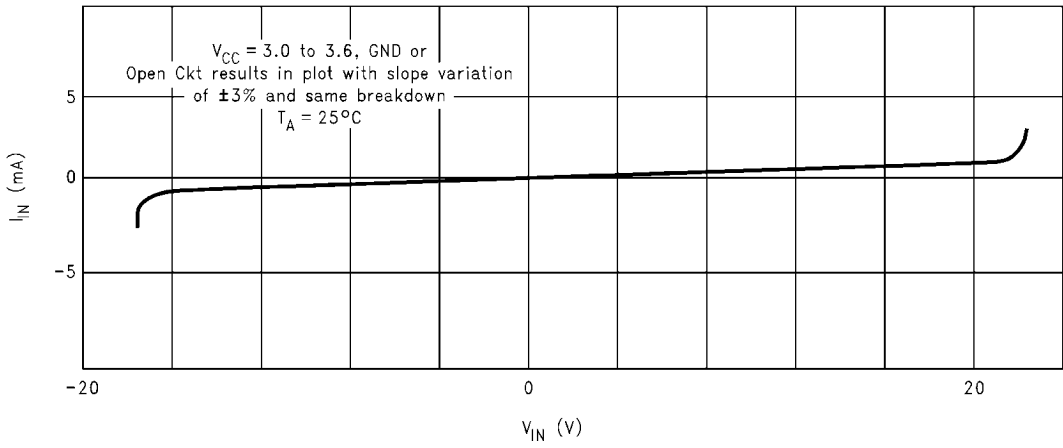

1264411

FIGURE 9. I_{IN} vs V_{IN} (Power On, Power Off)

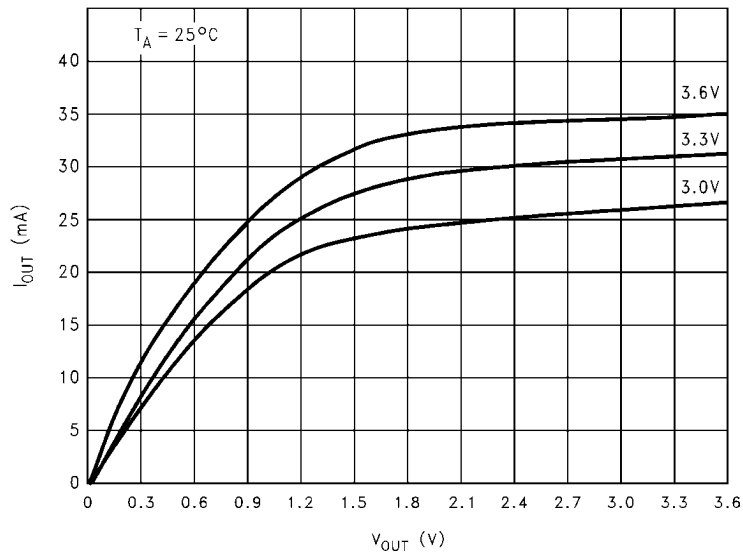

1264412

FIGURE 10. I_{OL} vs V_{OL}

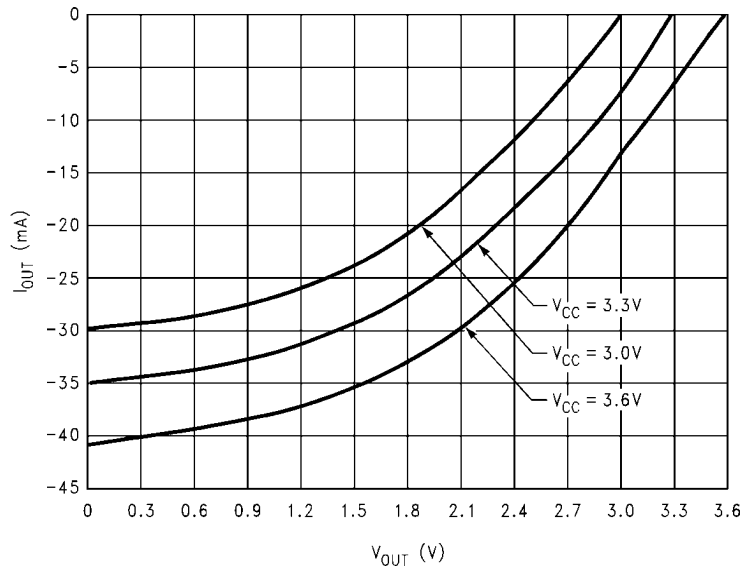

1264413

FIGURE 11. I_{OH} vs V_{OH}

Physical Dimensions inches (millimeters) unless otherwise noted

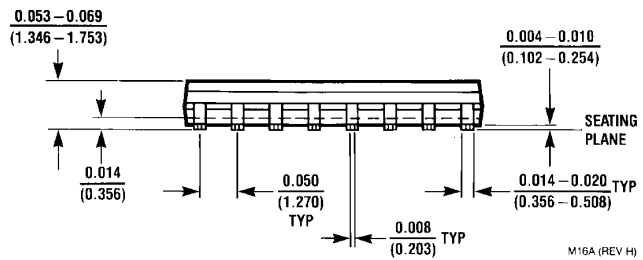
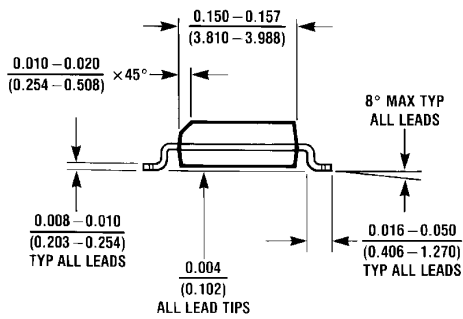
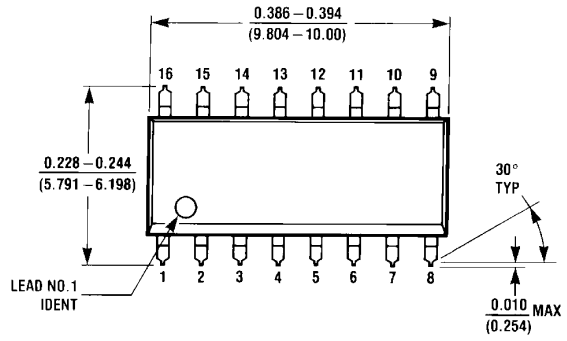

Dual-In-Line Package
Order Number DS34LV86TM
NS Package Number M16A

M16A (REV H)

Notes

For more National Semiconductor product information and proven design tools, visit the following Web sites at:

Products		Design Support	
Amplifiers	www.national.com/amplifiers	WEBENCH	www.national.com/webench
Audio	www.national.com/audio	Analog University	www.national.com/AU
Clock Conditioners	www.national.com/timing	App Notes	www.national.com/appnotes
Data Converters	www.national.com/adc	Distributors	www.national.com/contacts
Displays	www.national.com/displays	Green Compliance	www.national.com/quality/green
Ethernet	www.national.com/ethernet	Packaging	www.national.com/packaging
Interface	www.national.com/interface	Quality and Reliability	www.national.com/quality
LVDS	www.national.com/lvds	Reference Designs	www.national.com/refdesigns
Power Management	www.national.com/power	Feedback	www.national.com/feedback
Switching Regulators	www.national.com/switchers		
LDOs	www.national.com/ldo		
LED Lighting	www.national.com/led		
PowerWise	www.national.com/powerwise		
Serial Digital Interface (SDI)	www.national.com/sdi		
Temperature Sensors	www.national.com/tempsensors		
Wireless (PLL/VCO)	www.national.com/wireless		

THE CONTENTS OF THIS DOCUMENT ARE PROVIDED IN CONNECTION WITH NATIONAL SEMICONDUCTOR CORPORATION ("NATIONAL") PRODUCTS. NATIONAL MAKES NO REPRESENTATIONS OR WARRANTIES WITH RESPECT TO THE ACCURACY OR COMPLETENESS OF THE CONTENTS OF THIS PUBLICATION AND RESERVES THE RIGHT TO MAKE CHANGES TO SPECIFICATIONS AND PRODUCT DESCRIPTIONS AT ANY TIME WITHOUT NOTICE. NO LICENSE, WHETHER EXPRESS, IMPLIED, ARISING BY ESTOPPEL OR OTHERWISE, TO ANY INTELLECTUAL PROPERTY RIGHTS IS GRANTED BY THIS DOCUMENT.

TESTING AND OTHER QUALITY CONTROLS ARE USED TO THE EXTENT NATIONAL DEEMS NECESSARY TO SUPPORT NATIONAL'S PRODUCT WARRANTY. EXCEPT WHERE MANDATED BY GOVERNMENT REQUIREMENTS, TESTING OF ALL PARAMETERS OF EACH PRODUCT IS NOT NECESSARILY PERFORMED. NATIONAL ASSUMES NO LIABILITY FOR APPLICATIONS ASSISTANCE OR BUYER PRODUCT DESIGN. BUYERS ARE RESPONSIBLE FOR THEIR PRODUCTS AND APPLICATIONS USING NATIONAL COMPONENTS. PRIOR TO USING OR DISTRIBUTING ANY PRODUCTS THAT INCLUDE NATIONAL COMPONENTS, BUYERS SHOULD PROVIDE ADEQUATE DESIGN, TESTING AND OPERATING SAFEGUARDS.

EXCEPT AS PROVIDED IN NATIONAL'S TERMS AND CONDITIONS OF SALE FOR SUCH PRODUCTS, NATIONAL ASSUMES NO LIABILITY WHATSOEVER, AND NATIONAL DISCLAIMS ANY EXPRESS OR IMPLIED WARRANTY RELATING TO THE SALE AND/OR USE OF NATIONAL PRODUCTS INCLUDING LIABILITY OR WARRANTIES RELATING TO FITNESS FOR A PARTICULAR PURPOSE, MERCHANTABILITY, OR INFRINGEMENT OF ANY PATENT, COPYRIGHT OR OTHER INTELLECTUAL PROPERTY RIGHT.

LIFE SUPPORT POLICY

NATIONAL'S PRODUCTS ARE NOT AUTHORIZED FOR USE AS CRITICAL COMPONENTS IN LIFE SUPPORT DEVICES OR SYSTEMS WITHOUT THE EXPRESS PRIOR WRITTEN APPROVAL OF THE CHIEF EXECUTIVE OFFICER AND GENERAL COUNSEL OF NATIONAL SEMICONDUCTOR CORPORATION. As used herein:

Life support devices or systems are devices which (a) are intended for surgical implant into the body, or (b) support or sustain life and whose failure to perform when properly used in accordance with instructions for use provided in the labeling can be reasonably expected to result in a significant injury to the user. A critical component is any component in a life support device or system whose failure to perform can be reasonably expected to cause the failure of the life support device or system or to affect its safety or effectiveness.

National Semiconductor and the National Semiconductor logo are registered trademarks of National Semiconductor Corporation. All other brand or product names may be trademarks or registered trademarks of their respective holders.

Copyright© 2008 National Semiconductor Corporation

For the most current product information visit us at www.national.com



National Semiconductor Americas Technical Support Center
Email: support@nsc.com
Tel: 1-800-272-9959

National Semiconductor Europe Technical Support Center
Email: europe.support@nsc.com
German Tel: +49 (0) 180 5010 771
English Tel: +44 (0) 870 850 4288

National Semiconductor Asia Pacific Technical Support Center
Email: ap.support@nsc.com

National Semiconductor Japan Technical Support Center
Email: jpn.feedback@nsc.com

IMPORTANT NOTICE

Texas Instruments Incorporated and its subsidiaries (TI) reserve the right to make corrections, modifications, enhancements, improvements, and other changes to its products and services at any time and to discontinue any product or service without notice. Customers should obtain the latest relevant information before placing orders and should verify that such information is current and complete. All products are sold subject to TI's terms and conditions of sale supplied at the time of order acknowledgment.

TI warrants performance of its hardware products to the specifications applicable at the time of sale in accordance with TI's standard warranty. Testing and other quality control techniques are used to the extent TI deems necessary to support this warranty. Except where mandated by government requirements, testing of all parameters of each product is not necessarily performed.

TI assumes no liability for applications assistance or customer product design. Customers are responsible for their products and applications using TI components. To minimize the risks associated with customer products and applications, customers should provide adequate design and operating safeguards.

TI does not warrant or represent that any license, either express or implied, is granted under any TI patent right, copyright, mask work right, or other TI intellectual property right relating to any combination, machine, or process in which TI products or services are used. Information published by TI regarding third-party products or services does not constitute a license from TI to use such products or services or a warranty or endorsement thereof. Use of such information may require a license from a third party under the patents or other intellectual property of the third party, or a license from TI under the patents or other intellectual property of TI.

Reproduction of TI information in TI data books or data sheets is permissible only if reproduction is without alteration and is accompanied by all associated warranties, conditions, limitations, and notices. Reproduction of this information with alteration is an unfair and deceptive business practice. TI is not responsible or liable for such altered documentation. Information of third parties may be subject to additional restrictions.

Resale of TI products or services with statements different from or beyond the parameters stated by TI for that product or service voids all express and any implied warranties for the associated TI product or service and is an unfair and deceptive business practice. TI is not responsible or liable for any such statements.

TI products are not authorized for use in safety-critical applications (such as life support) where a failure of the TI product would reasonably be expected to cause severe personal injury or death, unless officers of the parties have executed an agreement specifically governing such use. Buyers represent that they have all necessary expertise in the safety and regulatory ramifications of their applications, and acknowledge and agree that they are solely responsible for all legal, regulatory and safety-related requirements concerning their products and any use of TI products in such safety-critical applications, notwithstanding any applications-related information or support that may be provided by TI. Further, Buyers must fully indemnify TI and its representatives against any damages arising out of the use of TI products in such safety-critical applications.

TI products are neither designed nor intended for use in military/aerospace applications or environments unless the TI products are specifically designated by TI as military-grade or "enhanced plastic." Only products designated by TI as military-grade meet military specifications. Buyers acknowledge and agree that any such use of TI products which TI has not designated as military-grade is solely at the Buyer's risk, and that they are solely responsible for compliance with all legal and regulatory requirements in connection with such use.

TI products are neither designed nor intended for use in automotive applications or environments unless the specific TI products are designated by TI as compliant with ISO/TS 16949 requirements. Buyers acknowledge and agree that, if they use any non-designated products in automotive applications, TI will not be responsible for any failure to meet such requirements.

Following are URLs where you can obtain information on other Texas Instruments products and application solutions:

Products

Audio	www.ti.com/audio
Amplifiers	amplifier.ti.com
Data Converters	dataconverter.ti.com
DLP® Products	www.dlp.com
DSP	dsp.ti.com
Clocks and Timers	www.ti.com/clocks
Interface	interface.ti.com
Logic	logic.ti.com
Power Mgmt	power.ti.com
Microcontrollers	microcontroller.ti.com
RFID	www.ti-rfid.com
OMAP Mobile Processors	www.ti.com/omap
Wireless Connectivity	www.ti.com/wirelessconnectivity

Applications

Communications and Telecom	www.ti.com/communications
Computers and Peripherals	www.ti.com/computers
Consumer Electronics	www.ti.com/consumer-apps
Energy and Lighting	www.ti.com/energy
Industrial	www.ti.com/industrial
Medical	www.ti.com/medical
Security	www.ti.com/security
Space, Avionics and Defense	www.ti.com/space-avionics-defense
Transportation and Automotive	www.ti.com/automotive
Video and Imaging	www.ti.com/video

TI E2E Community Home Page

e2e.ti.com

Mailing Address: Texas Instruments, Post Office Box 655303, Dallas, Texas 75265
Copyright © 2011, Texas Instruments Incorporated